

Safety Limit Switches with rope - Accessories

Stay Bolt

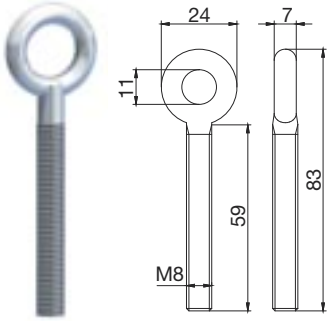

Code
OCC 08

Rope Clamp

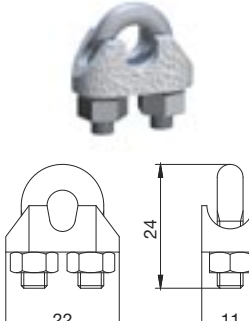

Code
MOR 05

Rope eye

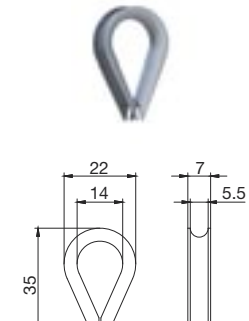

Code
RED 05

Rope \varnothing 5mm



Code	Length
FUN05M010	10m
FUN05M015	15m
FUN05M020	20m
FUN05M025	25m
FUN05M102	102m

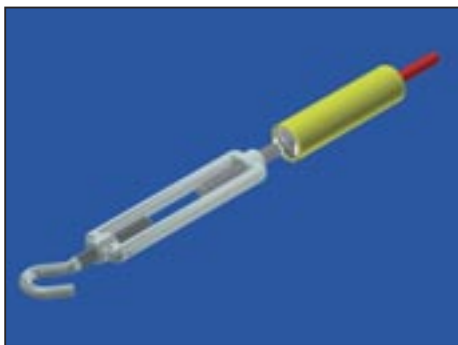

Code
SLS-FX1

Description
Hook stay bolt

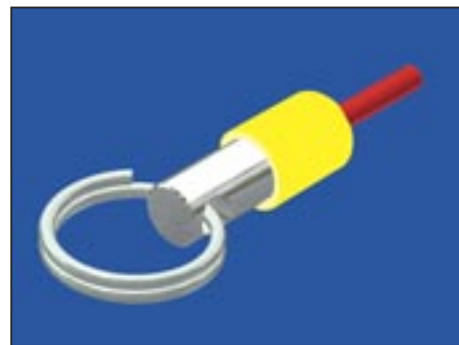
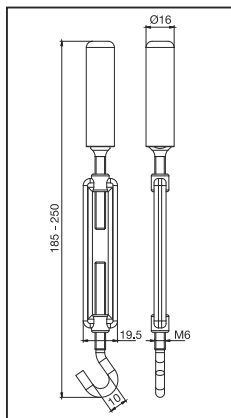

Code
SLS-FX2

Description
Fixing clamp

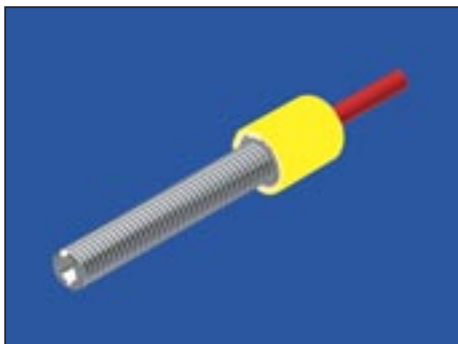
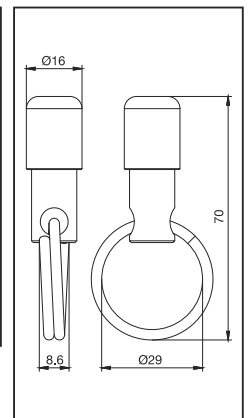

Code
SLS-FX3

Description
Stay bolt

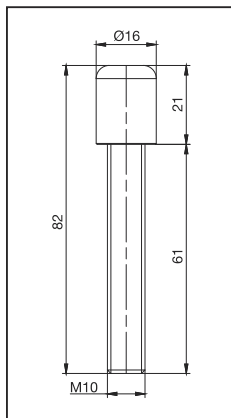

Code
SLS-M1

Description
Spring for SM, SDM series

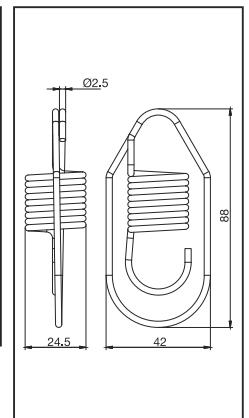

Code
SLS-M2

Description
Spring for SBM, SCM series

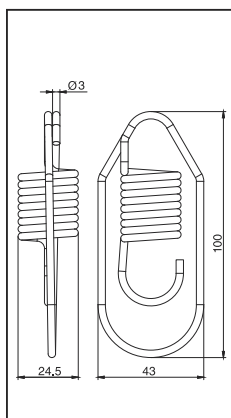

Safety Limit Switches with rope

Installation instructions

(fig. 1)

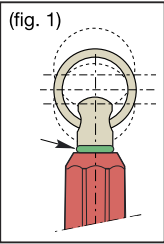

In order to obtain the correct operation of the device, please follow the following instructions.

1. Install the switch and secure the fixed end of the rope. Apply tension to the extent the green O-ring is visible and the bottom is flush with the end of the red housing. (Fig. 1).

2. Pull the reset pommel in order to close the safety contacts of the limit switch.
3. The contacts inside the limit switch will change their position whenever the rope is pulled or loose its tension.
4. Check the correct operation of the rope switch before you start the machine and periodically.

Performing the role of worker protection, improper installation or tampering with safety devices can cause serious injury to persons.

The installation must therefore be performed in accordance with local legislation and only by authorized personnel.

For any question about CE declaration of conformity or for any information and assistance, please contact our technical department

