

EBC HQ

99320

Item No:YYQ-120A

Ponchadora hidraulica 8AWG a 250MCM



Tipo de conector: Tubular

Número de Dados: 8

Tipos de Dados: 10, 16, 25, 35, 50, 70, 95, 120mm²

Rango de cable: 8 AWG - 250MCM

AWG	DIN
8	10
6	16
4	25
2	35
1/0	50
2/0	70
3/0	95
250 MCM	120

Peso neto: 4,20 Kgs

Accesorios: Caja Plastica (0,81Kg)

Fuerza: 12Ton.

Carrera: 14mm

Longitud: 425mm

Origen: China

Crimping range:	Cu 10–120mm ²
Crimping force:	12T
Crimping type:	hexagon crimping
Stroke:	14mm
Length:	approx.425mm
Weight:	approx.4.20kg
Package:	plastic box
Weight of box:	approx.0.81kg
Accessories: crimping dies: 10, 16, 25, 35, 50, 70, 95, 120mm ² Sealing O-ring: one set	

Instruction Manual

Hydraulic Crimping Tool YYQ-120A

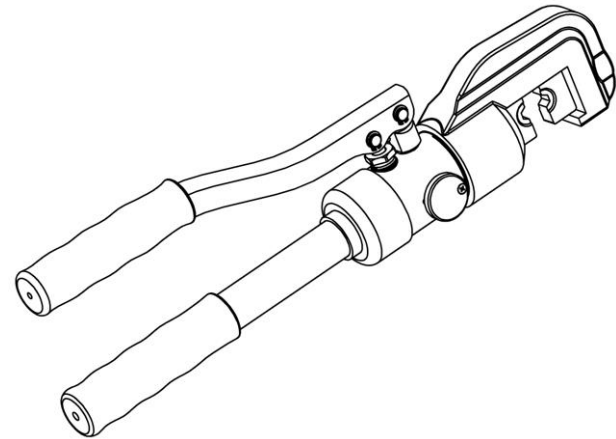

Due to continuing improvements, actual product may differ slightly from the product described herein.



Read this material before using this product.

Failure to do so can result in serious injury.

SAVE THIS MANUAL

SAVE THIS MANUAL

Keep this manual for the safety warnings and precautions, assembly, operating, inspection, maintenance and cleaning procedures. Write the month and year of purchase. Keep this manual and the receipt in a safe and dry place for future reference.

IMPORTANT SAFETY INFORMATION

In this manual, on the labeling, and all other information provided with this product:



This is the safety alert symbol. It is used to alert you to potential personal injury hazards. Obey all safety messages that follow this symbol to avoid possible injury or death.

▲DANGER

DANGER indicates a hazardous situation which, if not avoided, will result in death or serious injury.

▲WARNING

WARNING indicates a hazardous situation which, if not avoided, could result in death or serious injury.

▲CAUTION

CAUTION, used with the safety alert symbol, indicates a hazardous situation which, if not avoided, could result in minor or moderate injury.

LIMITED 1 YEAR WARRANTY

We make every effort to assure that its products meet high quality and durability standards, and warrants to the original purchaser that this product is free from defects in materials and workmanship for the period of one year from the date of purchase(90 days if used by a professional contractor or if used as rental equipment). This warranty does not apply to damage due directly or indirectly, to misuse, abuse, negligence or accidents, repairs or alterations outside our facilities, normal wear and tear, or to lack of maintenance. We shall in no event be liable for death, injuries to persons or property, or for incidental, contingent, special or consequential damages arising from the use of our product. Some states do not allow the exclusion or limitation of incidental or consequential damages, so the above limitation of exclusion may not apply to you. THIS WARRANTY IS EXPRESSLY IN LIEU OF ALL OTHER WARRANTIES, EXPRESS OR IMPLIED, INCLUDING THE WARRANTIES OF MERCHANTABILITY AND FITNESS.

To take advantage of this warranty, the product or part must be returned to us with transportation charges prepaid. Proof of purchase date and an explanation of the complaint must accompany the merchandise. If our inspection verifies the defect, we will either repair or replace the product at our election or we may elect to refund the purchase price if we cannot readily and quickly provide you with a replacement. We will return repaired products at our expense, but if we determine there is no defect, or that the defect resulted from causes not within the scope of our warranty, then you must bear the cost of returning the product.

The warranties give you specific legal rights and you may also have other rights which vary from place to place.

PLEASE READ THE FOLLOWING CAREFULLY

THE MANUFACTURER AND/OR DISTRIBUTOR HAS PROVIDED THE PARTS LIST AND ASSEMBLY DIAGRAM IN THIS MANUAL AS A REFERENCE TOOL ONLY. NEITHER THE MANUFACTURER NOR DISTRIBUTOR MAKES ANY REPRESENTATION OR WARRANTY OF ANY KIND TO THE BUYER THAT HE OR SHE IS QUALIFIED TO MAKE ANY REPAIRS TO THE PRODUCT, OR THAT HE OR SHE IS QUALIFIED TO REPLACE ANY PARTS OF THE PRODUCT. IN FACT, THE MANUFACTURER AND/OR DISTRIBUTOR EXPRESSLY STATES THAT ALL REPAIRS AND PARTS REPLACEMENTS SHOULD BE UNDERTAKEN BY CERTIFIED AND LICENSED TECHNICIANS, AND NOT BY THE BUYER. THE BUYER ASSUMES ALL RISK AND LIABILITY ARISING OUT OF HIS OR HER REPAIRS TO THE ORIGINAL PRODUCT OR REPLACEMENT PARTS THERETO, OR ARISING OUT OF HIS OR HER INSTRALLATION OF REPLACEMENT PARTS THERETO.

GENERAL SAFETY RULES

TO WORK IN SAFE CONDITIONS WITH THIS TOOLING, IT IS IMPERATIVE TO READ CAREFULLY THE DIRECTIONS FOR USE AND TO FOLLOW THE INSTRUCTIONS IT CONTAINS. IF YOU DO NOT RESPECT THE INFORMATION WRITTEN IN THAT INSTRUCTION MANUAL THE WARRANTY WILL BE CANCELLED.

1. Work area safety

- a. Keep work area clean and well lit. Cluttered or dark areas invite accidents.
- b. Keep children and bystanders away while operating, distractions will cause you to lose control.

2. Personal safety

- c. Stay alert, watch what you are doing and use common sense when operating the tool. Do not use the tool while you are tired or under the influence of drugs, alcohol or medication.. A moment of inattention while operating hydraulic tools may result in serious personal injury.
- d. Use safety equipment. Always wear eye protection. Safety equipment such as dust mask, non-skid shoes, hard hat, or hearing protection used for appropriate conditions will reduced personal injuries.
- e. Dress properly. Do not wear loose clothing or jewelry. Keep your hair, clothing and gloves away from moving parts. Loose clothes jewelry or long hair can be caught in moving parts.
- f. Do not force the tool. Use the correct power tool for your application .The correct power tool will do the job better and safer at the rate for which it was designed.

- g. Store idle power tools out of the reach of children and do not allow persons unfamiliar with the hydraulic crimping tool. This tool is dangerous in the hands of untrained users.
- h. Maintain power tools. Check for misalignment or binding of moving parts, breakage of parts and any other condition that may affect the Hydraulic crimping tool operation. If damaged, have the Hydraulic crimping tool repaired before use. Many accidents are caused by poorly maintained power tools.
- i. Use the Hydraulic Crimping Tool, accessories and tool bits etc., in accordance with these instructions and in the manner intended for the particular type of tool, taking into account the working conditions and the work to be performed. Use of the Hydraulic Crimping tool for operations different from those intended could result in a hazardous situation.

3. Service

Have your Hydraulic Crimping Tool serviced by a qualified service technician using only identical replacement parts. This will ensure that the safety of the Hydraulic Crimping Tool Kit is maintained.

No	Description	Qty	No	Description	Qty
1	magnet part	2	21	bolt	1
2	pin	2	22	copper gasket 18x12x1	1
3	die	1 set	23	Bolt M3x10	1
4	head	1	24	screw	1
5	spring	1	25	O-ring 4x2	1
6	piston	1	26	plunger	1
7	plastic retainer ring 35x29x1.2	1	27	steel ball C5	1
8	O-ring 35x3.5	1	28	Pin 3x10	1
9	valve	1	29	valve	1
10	spring	1	30	spring	1
11	steel ball C6	1	31	steel ball C4	1
12	steel ball C4	1	32	cylinder	1
13	stander	1	33	Oil cup	1
14	plunger	1	34	filter sieve 120M	1
15	pin	2	35	plastic retainer ring	1
16	retainer ring	4	36	O-ring 29.8x3.1	1
17	active handle	1	37	oil sac	1
18	handle sleeve	1	38	Plug cock	1
19	plastic retainer ring 13.8x10.6x1.2	2	39	fixed handle	1
20	O-ring 10x2	2	40	handle cover	1

PART LIST

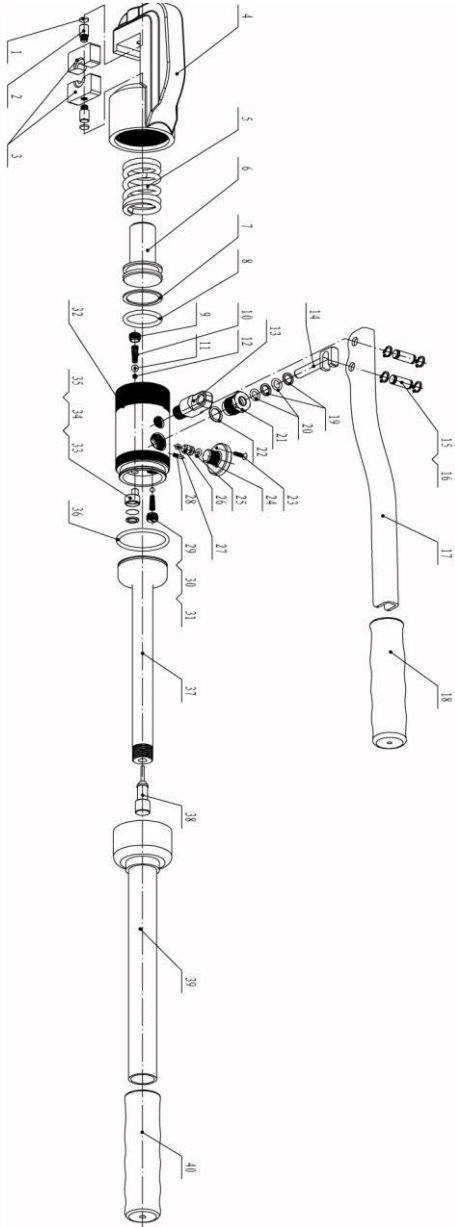

SPECIFIC SAFETY RULES

1. Maintain labels and nameplates on the tool which carry important safety information. If unreadable or missing, contact the agent to replace.
2. This product is not a toy, keep it out of reach of children.
3. Do not slide your fingers in the dies profile.
4. Do not put your fingers in the head of the hydraulic crimping tool when you slide the dies inside it. Your fingers could be pinched very severely.
5. Do not use the tool without die.
6. Do not crimp on live cables or conductors
7. Do only crimp cooper or Al conducting material
8. The warnings, precautions, and instructions discussed in this instruction manual cannot cover all possible conditions and situations that may occur. It must be understood by the operator that common sense and caution are factors which cannot be built into this product, but must be supplied by the operator.



SAVE THESE INSTRUCTION

UNDERSTAND YOUR TOOL

YYQ-120A is a tool for connecting lugs and cable. It carries many advantages of good design, easy operation, high pressure, high efficiency and etc. It is a perfect tool to be used in electrical construction site.

1. Specification

Crimping range:	Cu 10-120mm ²
Crimping force:	60KN
Crimping type:	hexagon crimping
Stroke:	16mm
Hydraulic oil:	15# hydraulic oil
Ambient temperature:	-10°C-40°C
Length:	approx 425mm
Weight:	approx 3.20kg
Package:	plastic box
Weight of box:	approx 0.90kg
Accessories	
crimping die:	10.16.25.35.50.70.95.120 mm ²
sealing O-ring:	one set



The dust or air inside the tool will damage the sealing kit so caused the tool lose function. Make sure the oil is clear and no dust entering into oil when changing oil. Wait for a while and exhaust the oil completely out of the oil tube before inserting the oil plug.

⚠CAUTION

Please wear the rubber gloves to avoid skin touching the oil directly, if touches it in careless, please wash the skin by soap water in timely. In order to protect the environment please drain the waste oil to the treatment center where was approved by government.

Troubleshooting

FAULT	ANALYSIS	SOLUTION
A. No pressure or the pressure is not enough during operation	<ol style="list-style-type: none"> 1. The pump lack oil 2. There is dust exist in oil 3. Inner leakage 	<ol style="list-style-type: none"> 1. Fulfill or replace the oil 2. Change the oil 3. Contact manufacturer or distributor
B. The lug and wire do not connect tightly after crimping.	<ol style="list-style-type: none"> 1. The tool can not reach to the rated pressure 2. Use the wrong die 	<ol style="list-style-type: none"> 1. Refer to the fault A 2. Replace with the right die
C. Generate a lot of burs after crimping	<ol style="list-style-type: none"> 1. Use the wrong die 	<ol style="list-style-type: none"> 1. Replace with the right die
D. Oil leakage on the head or on the ram	<ol style="list-style-type: none"> 1. Sealing kit broken 	<ol style="list-style-type: none"> 1. Contact manufacturer or distributor and replace it by trained person

MAINTENANCE AND SERVICING

⚠WARNING

Damaged equipment may cause serious personal injury. Do not use damaged equipment. If abnormal noise or vibration occurs, have the problem corrected before further using.

1. **Before each using**, inspect the general condition of the tool. Check for loose screws, misalignment or binding of moving parts, cracked or broken parts, or any other condition that may affect its safe operation.
2. **After using**, clean external surfaces of the tool with clean, moist, smear the rust preventing oil on the metal surface of the tool and the dies to avoid rusty. Store the tool in the dry environment.
3. Service to the tool should only be done by a qualified Service Technician.
4. In order to prolong the life of the tool please change the oil per year. Make sure the oil filtered by 120 mesh net or over 30µm strainer. Meantime avoid the dusty into the oil cup.
5. After a long time using, the sealing kits will be damaged, if there is leakage please contact with the manufacturer and/or the distributor to change the sealing kits.

How to change oil:

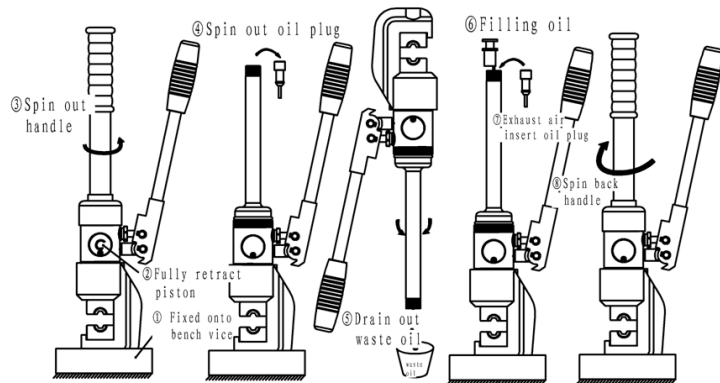

2. Description of the components

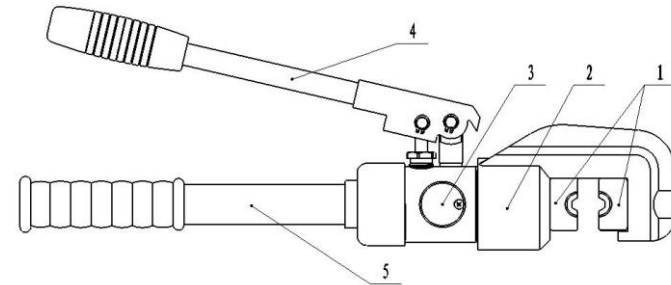

Item no.	Description	Function
1	Die	For crimping, interchangeable crimping dies
2	Down die holder	For fixing the down die
3	Screw	For returning piston and releasing pressure
4	Active handle	For operating
5	Fixed handle	For storing oil

3. Function Description

1) "C" type crimping head

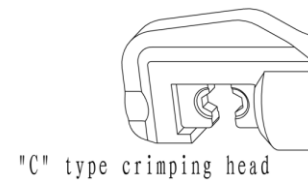

2) Release the pressure manually.



OPERATING INSTRUCTIONS

Read the entire **SAFETY INFORMATION** section at the beginning of this manual including all text under subheadings therein before using this product.

CAUTION

Please do not knock any part of the tool; otherwise it is dangerous for operator.

1. Select the appropriate die set. Ask an authorized facility or distributor to choose proper compression die set for the connector and cable being used.

CAUTION Don't operate the tool without dies.

2. Insert the down die, put cable into head, then insert the upper die to make cable between two dies, the tool is ready to operate.

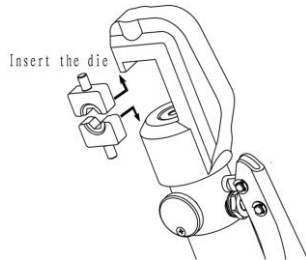

3. Pump the handle until reach to the maximum pressure, then spin the screw to release the pressure manually.

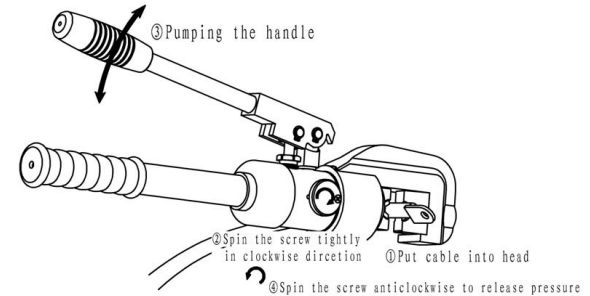

CAUTION

The tool is not insulated, please do not use it on the live conductor to avoid injury occurring.

DANGER

Do not put your fingers into the head of the tool during operating. Your fingers could be pinched very severely.

4. The piston will retract, take out the cable. The tool is ready for its next cycle.

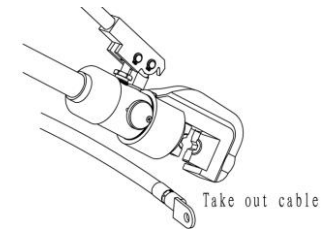

Standard die size: 10.16.25.35.50.70.95.120 mm²

