

- 采用热塑性外壳，结构紧凑，安装方便；
- 可加装防护套，能防油、防尘；
- 有手动复位与自动复位，灵活选择；
- 广泛应用于各种电子设备、自动化设备、通讯设备、仪器仪表等领域作电源通断与连接电路用。
- Adaptador termoplástico, construcción compacta e instalación simple.
- Se puede instalar la tapa protectora, material contra aceite y a prueba de polvo.
- Reinicio manual y reinicio automático para una elección flexible.
- Ampliamente utilizado en equipos eléctricos, máquinas automáticas, equipos e instrumentos de comunicación, herramientas de electro movimiento, etc.

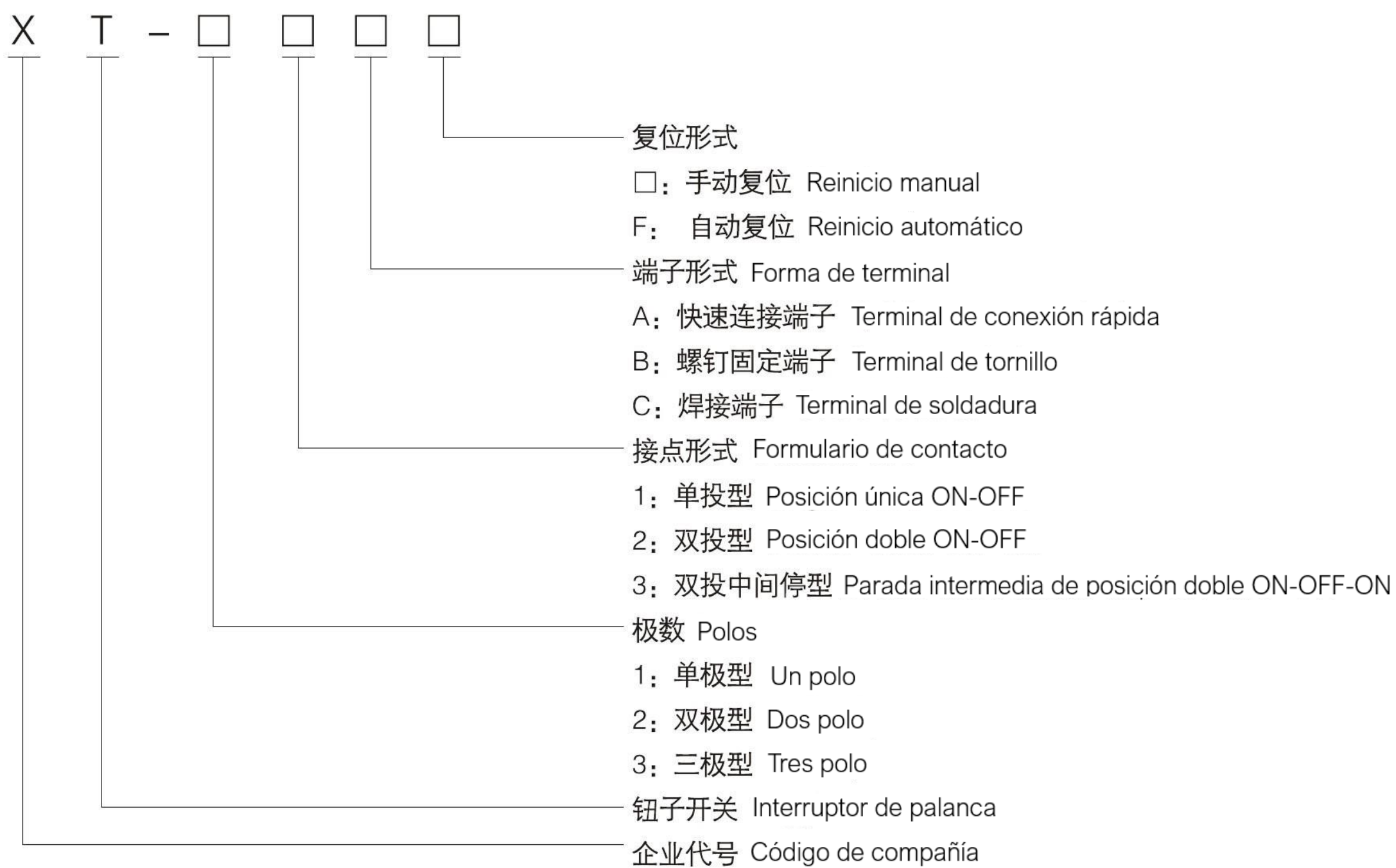

### □ 型号含义 Modelo & Significados



### □ 安装孔尺寸及结构图 Orificios de montaje & estructura del producto

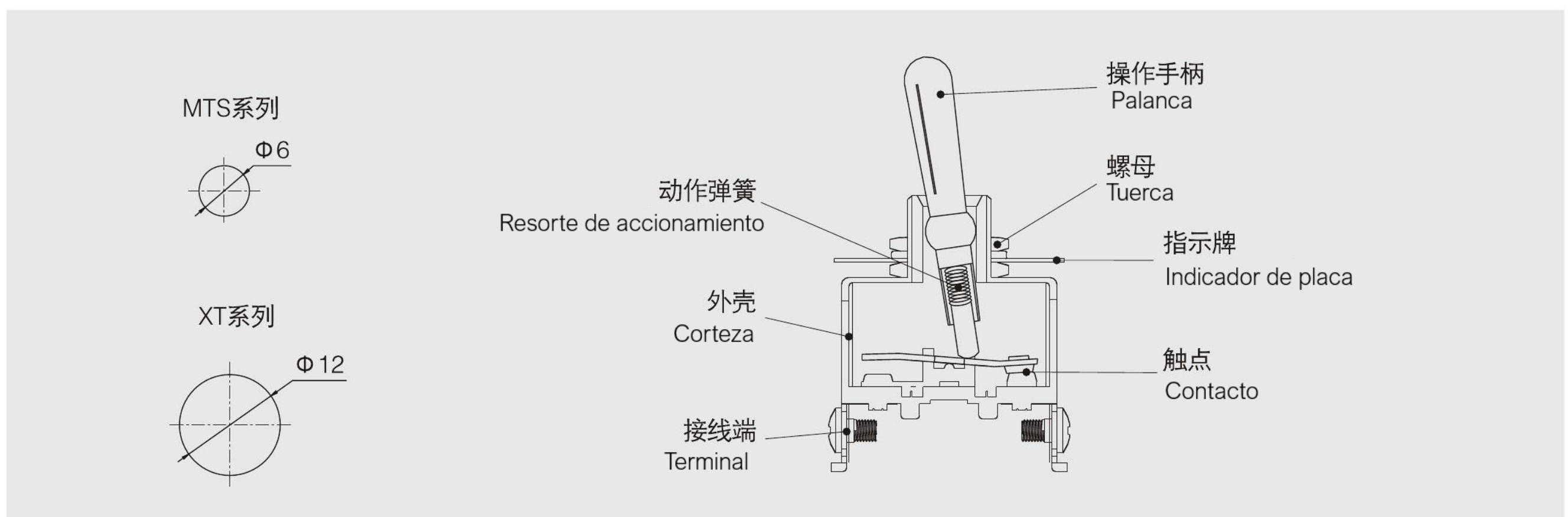

□ 性能参数 Especificaciones

项 目 Item	参数值 Datos	
额定负载 Carga nominal	15A/250VAC, 25A/250VAC MTS: 6A/125,250V	
操作频率 Frecuencia de operación	30次/分 30 veces/min	
绝缘电阻 Resistencia de aislamiento	100MΩ 以上( Por arriba ) DC500V	
接触电阻 Resistencia de contacto	25mΩ(初值 Valor inicial )	
介质耐压 Tensión soportada	非 连线 Cable sin conexión	1000VAC
	各端子间 Cada terminal	1500VAC
振 动 Vibración	误 动作 Mal funcionamiento	10-55Hz 复振幅 Amplitud : 1.5mm
冲 击 Impacto	耐 久 Duración	1000m/s <sup>2</sup>
	误 动作 Mal funcionamiento	300m/s <sup>2</sup>
寿 命 Vida	电 气 Eléctrico	100,000次以上 Por arriba
	机 械 Mecánico	500,000次以上 Por arriba
防护等级 Grado de protección	IP40	
使用温度 Temperatura de operación	-25~+80°C	
使用湿度 Humedad de operación	<85%	

□ 端子类型 Formas de terminales

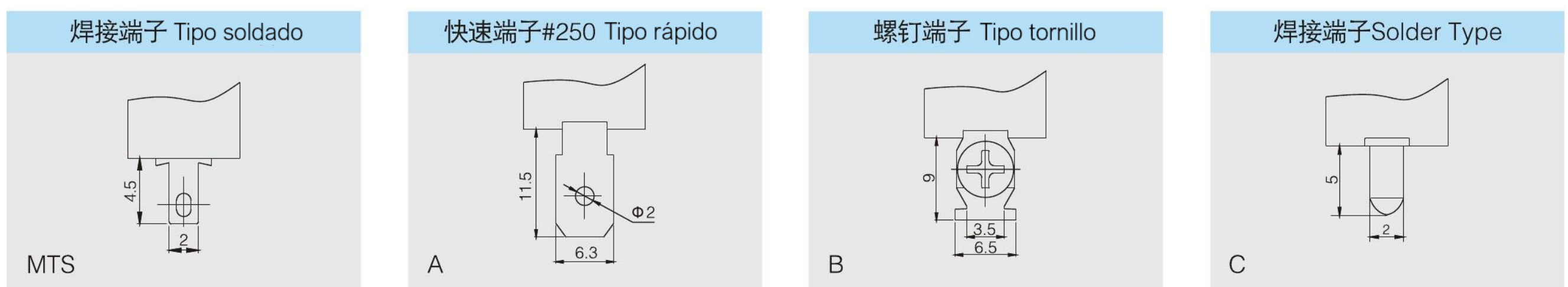

□ 外形尺寸 Dimensiones

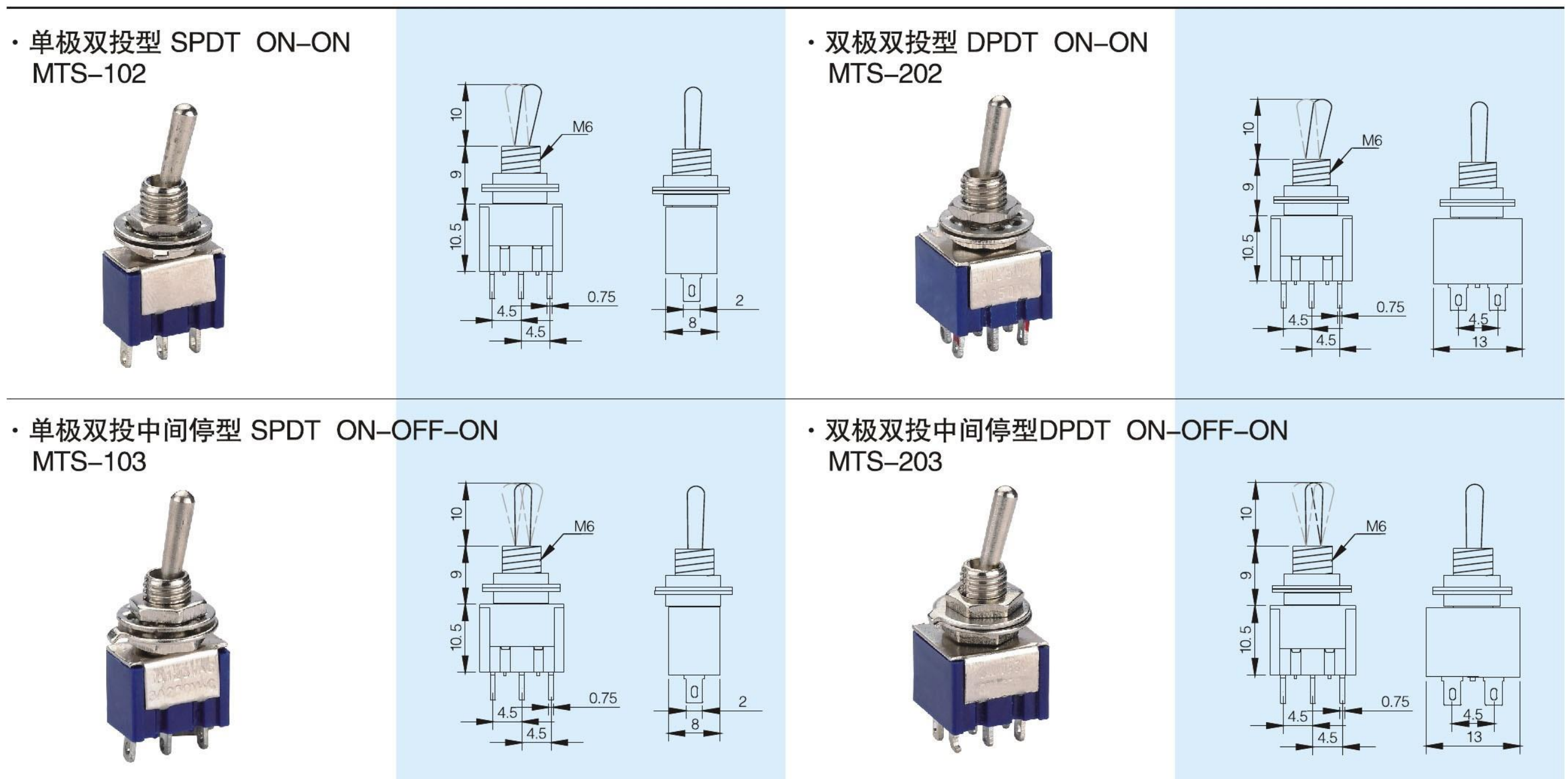

• 单极单投型 SPST ON-OFF  
XT-11B

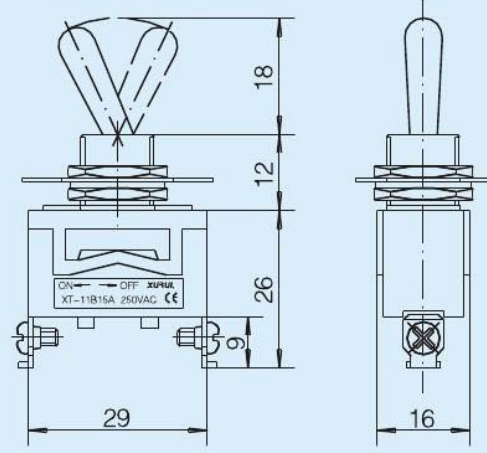

• 双极双投中间停型 DPDT ON-OFF-ON  
XT-23B

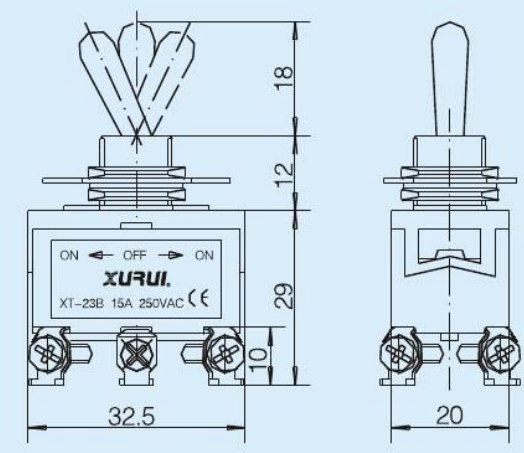

• 单极双投型 SPDT ON-ON  
XT-12B

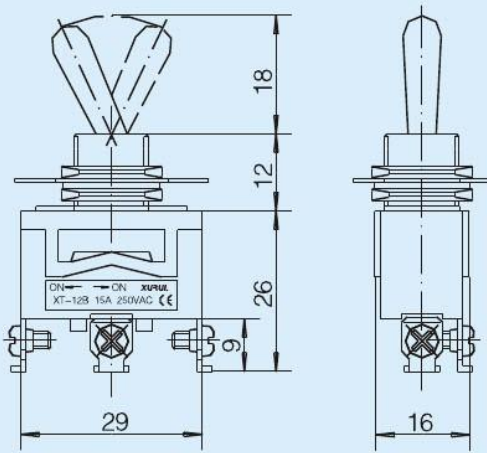

• 单极单投型 SPST ON-OFF  
XT-11A

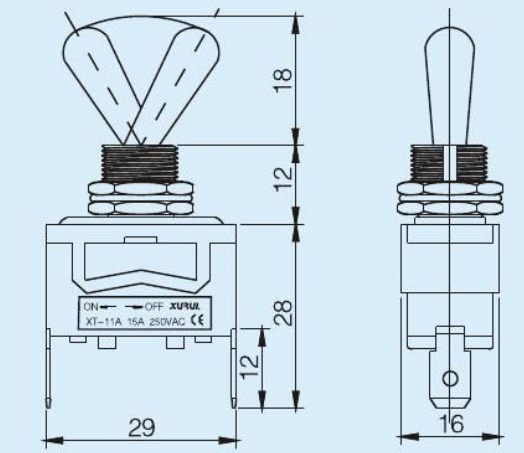

• 单极双投中间停型 SPDT ON-OFF-ON  
XT-13B

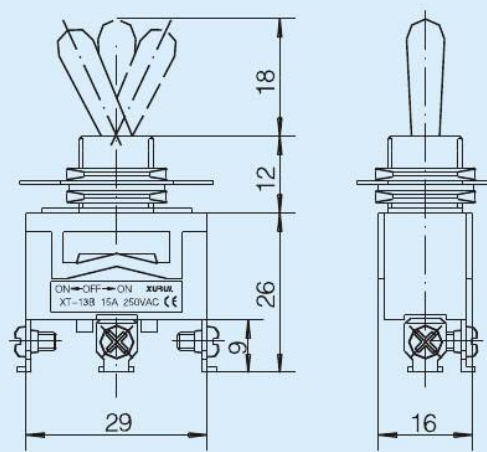

• 单极双投型 SPDT ON-ON  
XT-12A

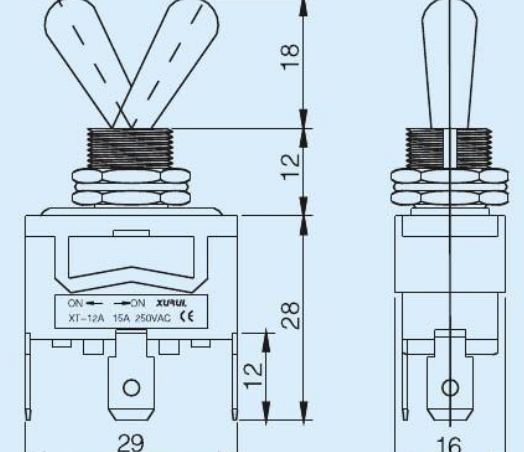

• 双极单投型 DPST ON-OFF  
XT-21B

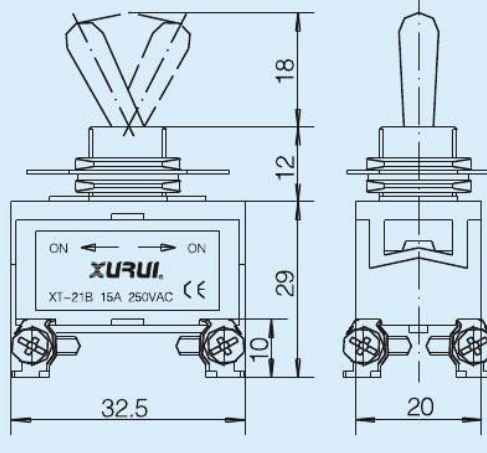

• 单极双投中间停型 SPDT ON-OFF-ON  
XT-13A

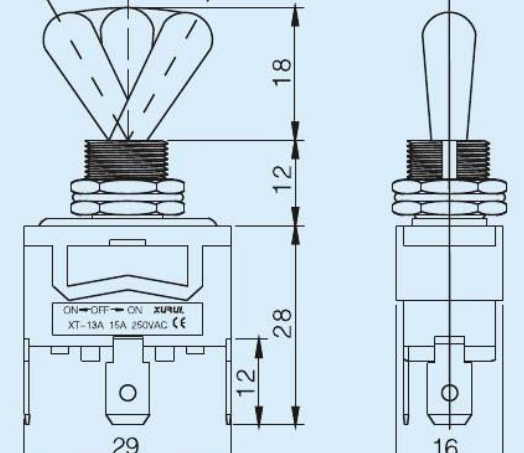

• 双极双投型 DPDT ON-ON  
XT-22B

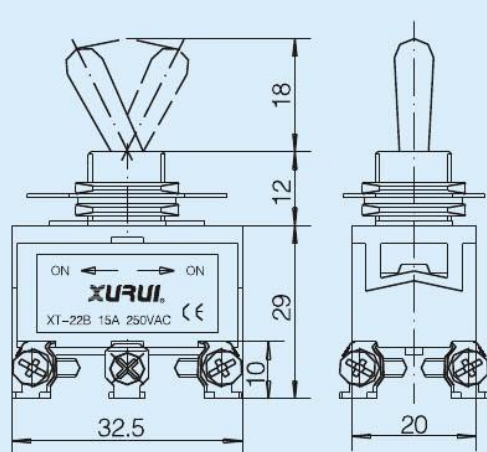

• 双极单投型 DPST ON-OFF  
XT-21A

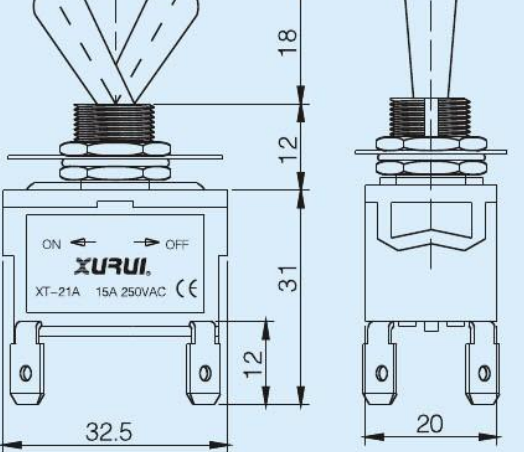

• 双极双投型 DPDT ON-ON  
XT-22A

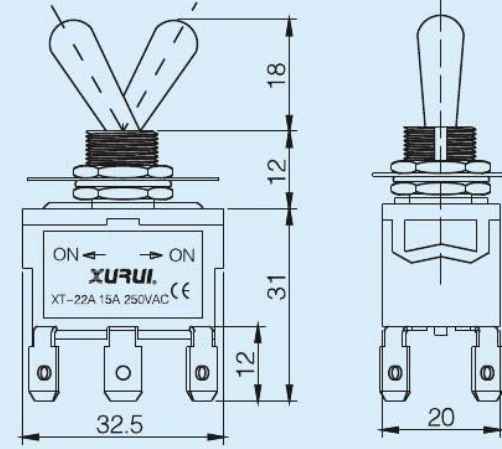

• 双极双向自动复位型 DPDT REINICIO AUTOMATICO (ON)-OFF-(ON)  
XT-23BF

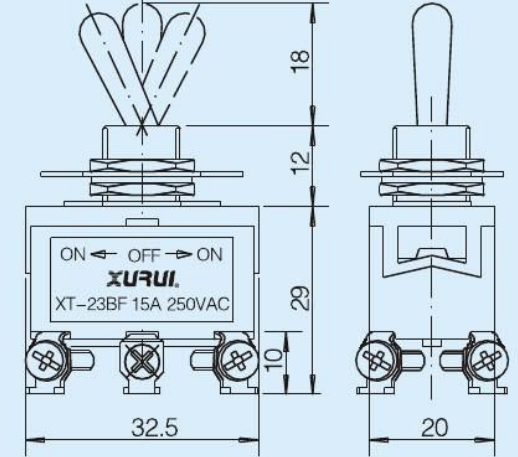

• 双极双投中间停型 DPDT ON-OFF-ON  
XT-23A

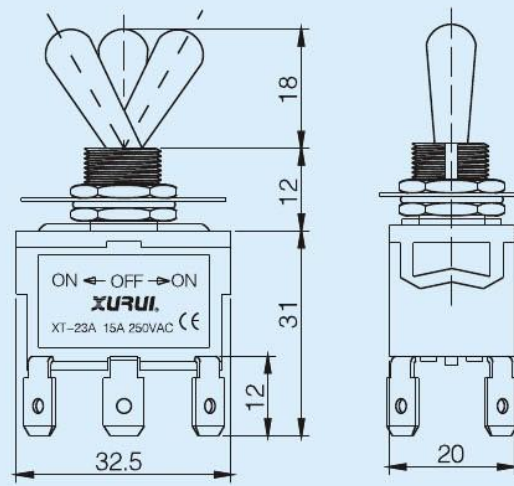

• 单极单向自动复位型 SPST REINICIO AUTOMATICO (ON)-OFF-(ON)  
XT-11AF

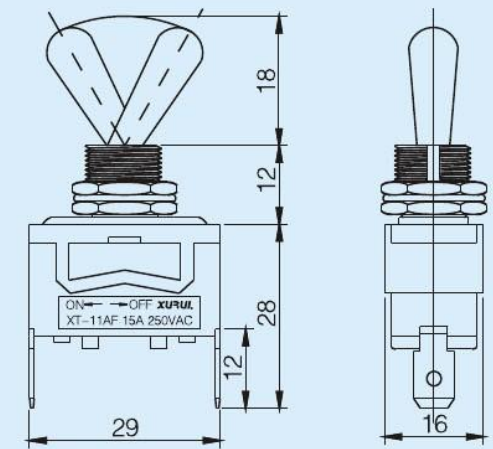

• 单极单向自动复位型 SPST REINICIO AUTOMATICO (ON)-OFF  
XT-11BF

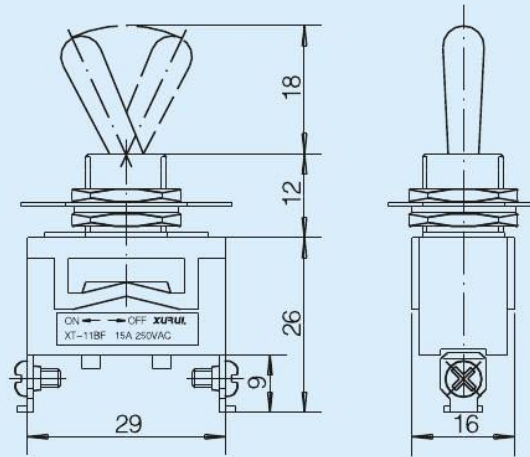

• 单极双向自动复位型 SPDT REINICIO AUTOMATICO (ON)-OFF-(ON)  
XT-13AF

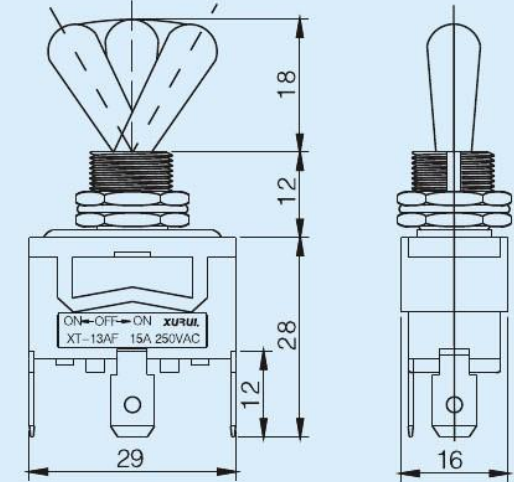

• 单极双向自动复位型 SPDT REINICIO AUTOMATICO (ON)-OFF-(ON)  
XT-13BF

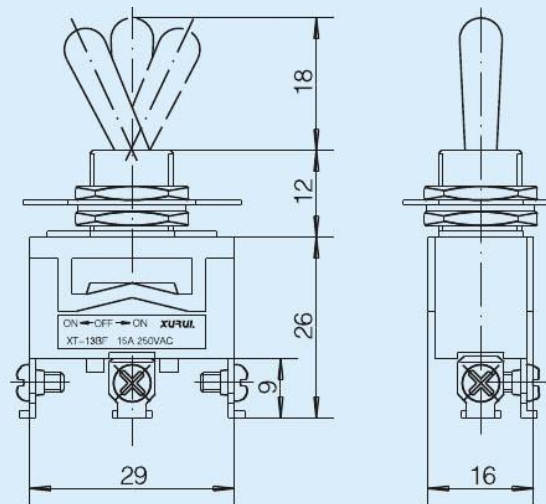

• 双极单向自动复位型 DPST REINICIO AUTOMATICO (ON)-OFF  
XT-21AF

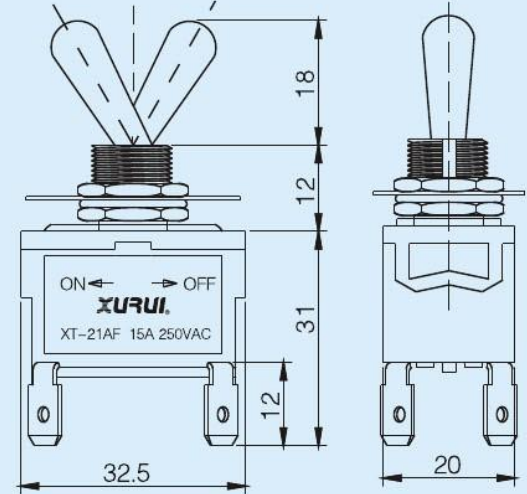

• 双极单向自动复位型 DPST REINICIO AUTOMATICO (ON)-OFF  
XT-21BF

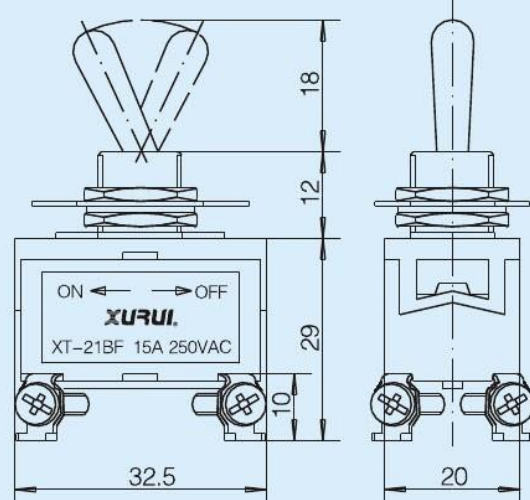

• 双极双向自动复位型 DPDT REINICIO AUTOMATICO (ON)-OFF-(ON)  
XT-23AF

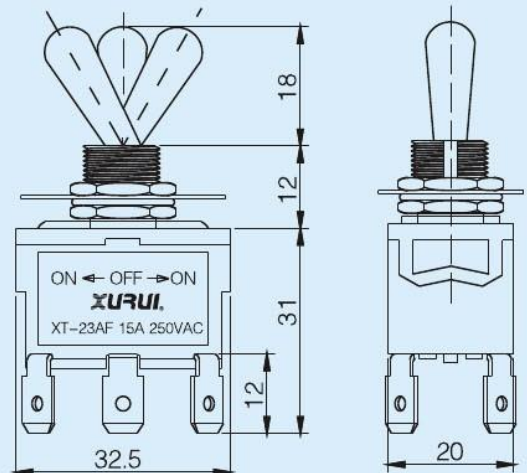

• 单极单投型 SPST ON-OFF  
XT-11C

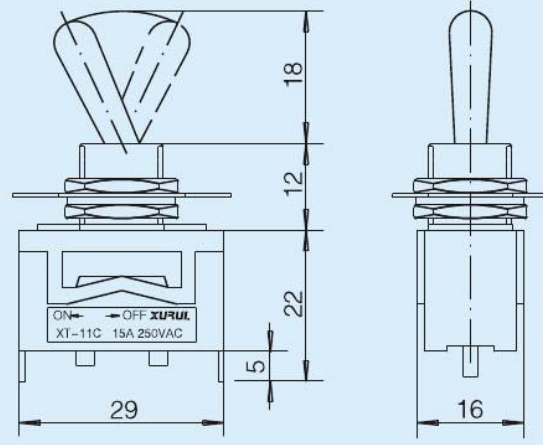

• 双极双投中间停型 DPDT ON-OFF-ON  
XT-23C

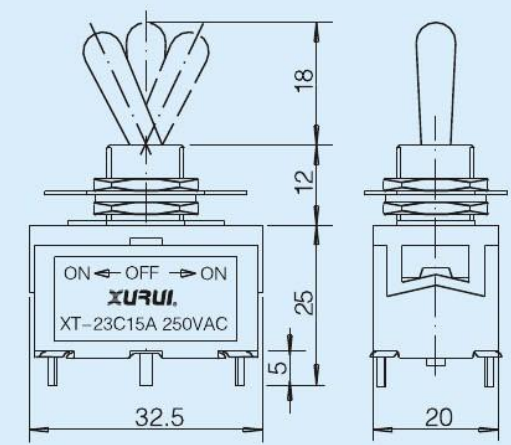

• 单极双投型 SPDT ON-ON  
XT-12C

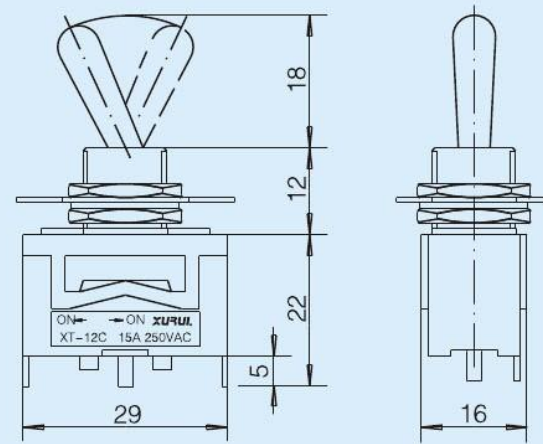

• 单极单向自动复位型 SPST REINICIO AUTOMATICO (ON)-OFF  
XT-11CF

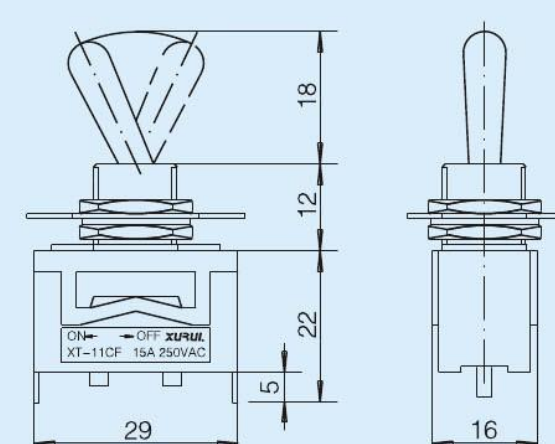

• 单极双投中间停型 SPDT ON-OFF-ON  
XT-13C

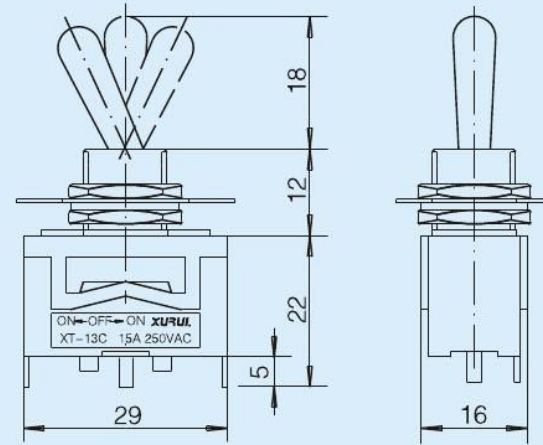

• 单极双向自动复位型 SPDT REINICIO AUTOMATICO (ON)-OFF-(ON)  
XT-13CF

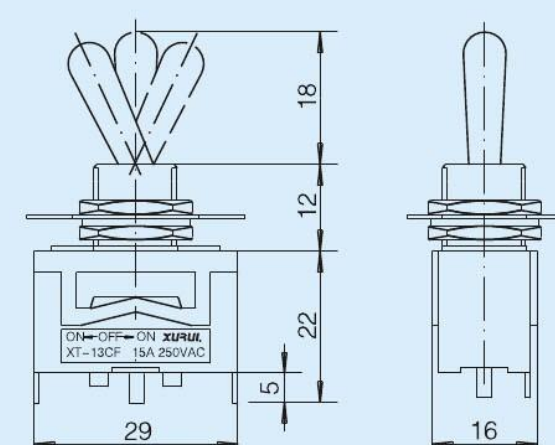

• 双极单投型 DPST ON-OFF  
XT-21C

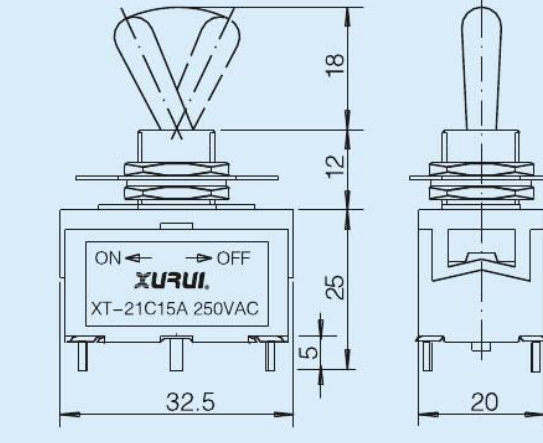

• 双极单向自动复位型 DPST REINICIO AUTOMATICO (ON)-OFF  
XT-21CF

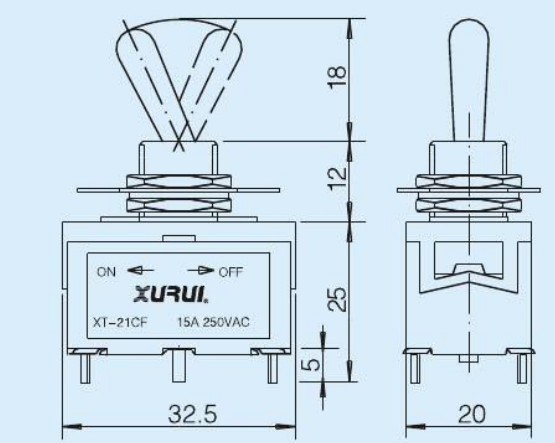

• 双极双投型 DPDT ON-ON  
XT-22C

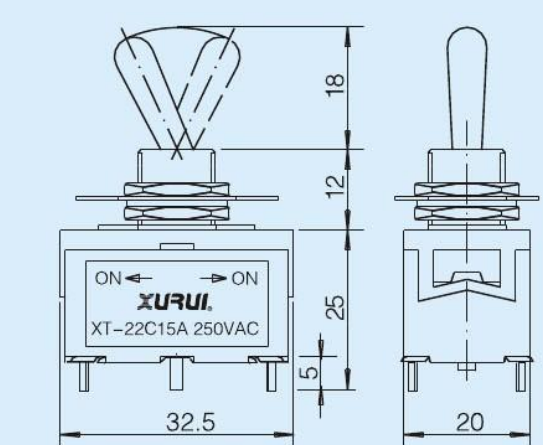

• 双极双向自动复位型 DPDT REINICIO AUTOMATICO (ON)-OFF-(ON)  
XT-23CF

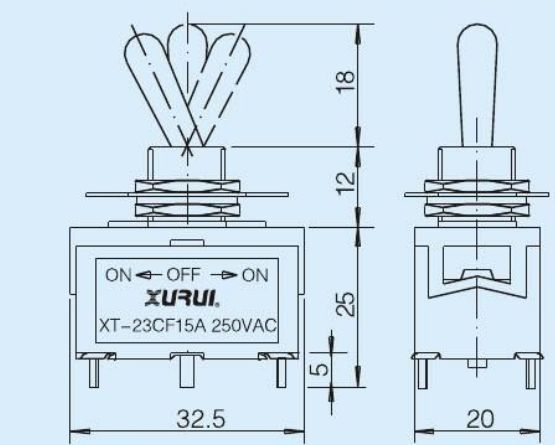

• 三极极单投型 TPST ON-OFF  
XT-31B

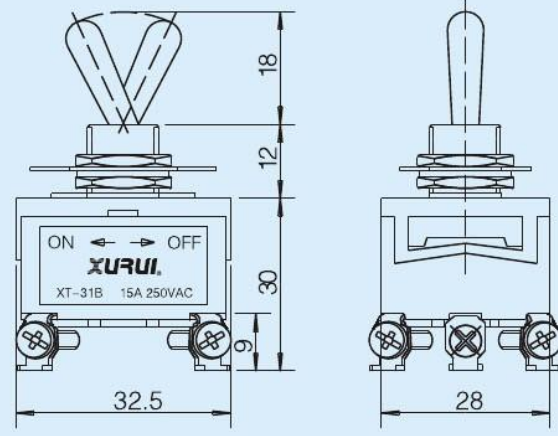

• 三极极单投型 TPST ON-OFF  
XT-31A

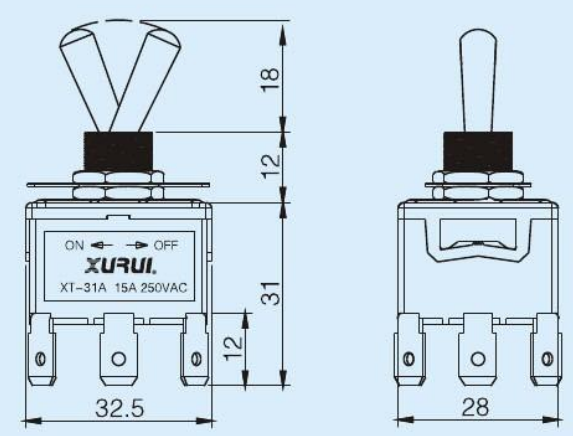

• 三极双投型 TPDT ON-ON  
XT-32B

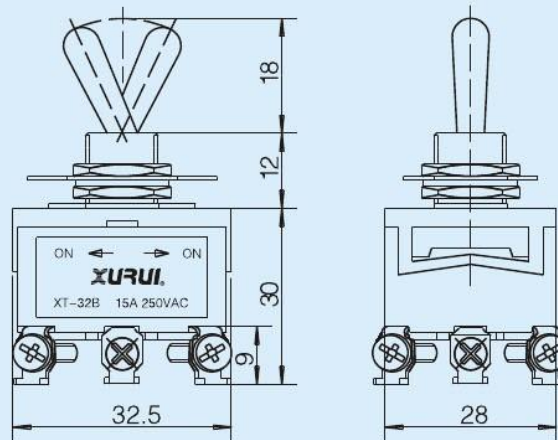

• 三极双投型 TPDT ON-ON  
XT-32A

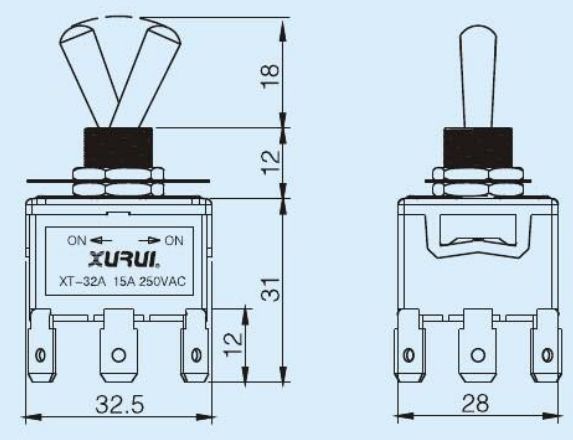

• 三极双投中间停型 TPDT ON-OFF-ON  
XT-33B

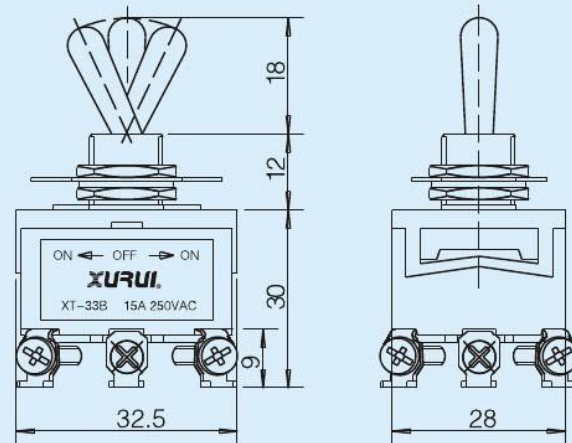

• 三极双投中间停型 TPDT ON-OFF-ON  
XT-33A

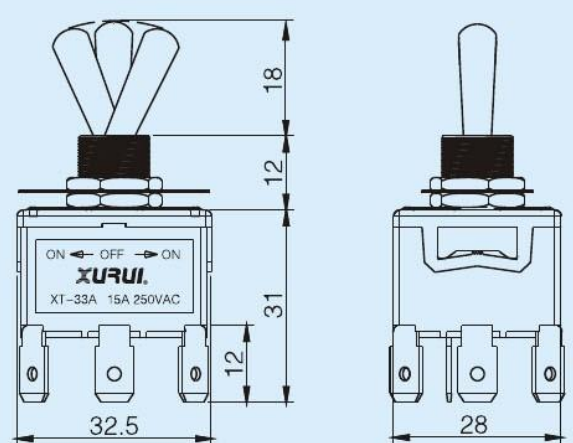

• 三极单向自动复位型 TPST REINICIO AUTOMATICO (ON)-OFF  
XT-31BF

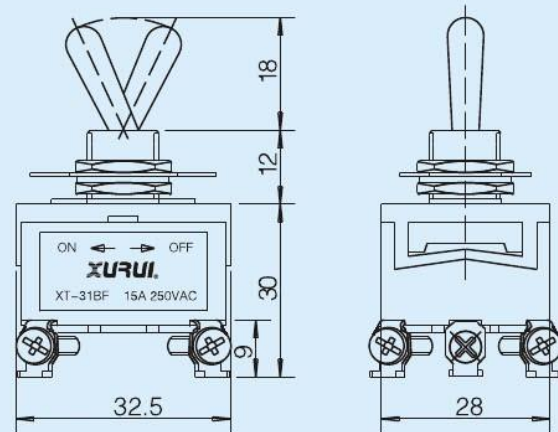

• 钮子开关防护套 CAPA DE PROTECCION  
XT-HT

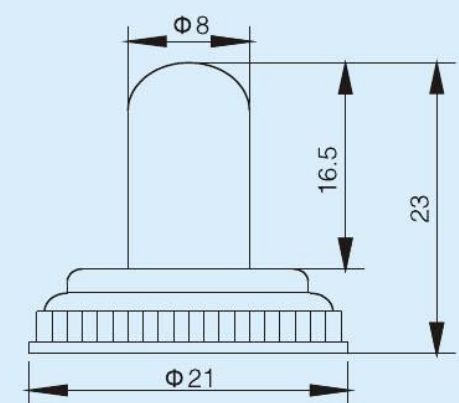

• 三极双向自动复位型 TPDT REINICIO AUTOMATICO (ON)-OFF-(ON)  
XT-33BF

